

## SUPER MULTIPLE JUNCTION (SMJ)

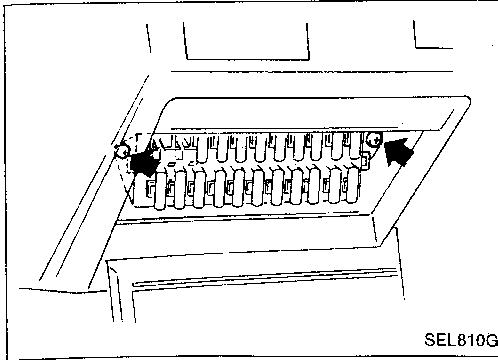

### REMOVAL

- Remove fuse block retaining screws to gain access to SMJ.
- Slide fuse block to the side, and remove SMJ retaining bolts to detach SMJ.

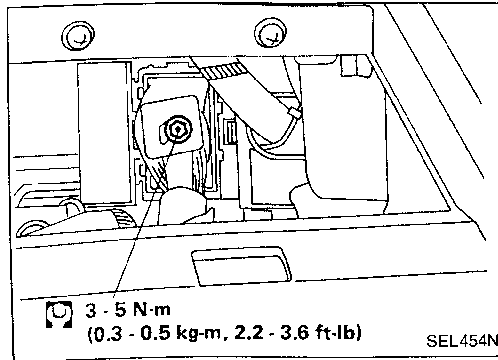

### INSTALLATION

To install SMJ, tighten bolts until orange "fulltight" mark appears and then retighten to specified torque as required.

: 3 - 5 N-m (0.3 - 0.5 kg-m, 2.2 - 3.6 ft-lb)

### CAUTION:

**Do not overtighten bolts, otherwise, bolts may be damaged.**

# SUPER MULTIPLE JUNCTION (SMJ)

## Terminal Arrangement

### MAIN HARNESS

VG30E engine model

KA24E engine model



H1	J1	K1	L1	M1	N1
H2	J2	K2	L2	M2	N2
H3	J3	K3	L3	M3	
H4	J4	K4	L3	M4	N4
H5	J5	K5		M5	N5
H6					N6
H7					N7
H8					N8
H9					N9
H10					N10
H11					N11
H12	J12	K12		M12	N12
H13	J13	K13	L14	M13	N13
H14	J14	K14	L15	M14	
H15	J15	K15	L16	M15	N15
H16	J16	K16	L16	M16	N16

A1	B1	C1	D1	E1	F1	G1
A2	B2	C2	D2	E2	F2	G2
A3	B3	C3		E3	F3	G3
A4	B4				F4	G4
A5	B5				F5	G5
A6	B6				F6	G6
A7	B7				F7	G7
A8	B8	C8	D9	E8	F8	G8
A9	B9	C9	D10	E9	F9	G9
A10	B10	C10		E10	F10	G10

N1	M1	L1	K1	J1	H1
N2	M2	L2	K2	J2	H2
N3	M3	L3	K3	J3	H3
N4	M4	L3	K4	J4	H4
N5	M5		K5	J5	H5
N6					H6
N7					H7
N8					H8
N9					H9
N10					H10
N11					H11
N12	M12		K12	J12	H12
N13	M13	L14	K13	J13	H13
N14	M14	L15	K14	J14	H14
N15	M15	L16	K15	J15	H15
N16	M16	L16	K16	J16	H16

A10	B10	C10	D10	E10	F10	G10
A9	B9	C9	D9	E9	F9	G9
A8	B8	C8	D9	E8	F8	G8
A7	B7				F7	G7
A6	B6				F6	G6
A5	B5				F5	G5
A4	B4				F4	G4
A3	B3	C3	D2	E3	F3	G3
A2	B2	C2	D1	E2	F2	G2
A1	B1	C1		E1	F1	G1

### INSTRUMENT HARNESS

### ECM (ECCS CONTROL MODULE)

101	102	103	104	105	106	107	108	1	2	3	4	5	6	7	15	16	17	18	19	20	21	22	31	32	33	34	35	36	37	38	39
109	110	111	112	113	114	115	116	8	9	10	11	12	13	14	23	24	25	26	27	28	29	30	40	41	42	43	44	45	46	47	48

View from harness side



# 1994 NISSAN TRUCK/PATHFINDER CIRCUIT DIAGRAM

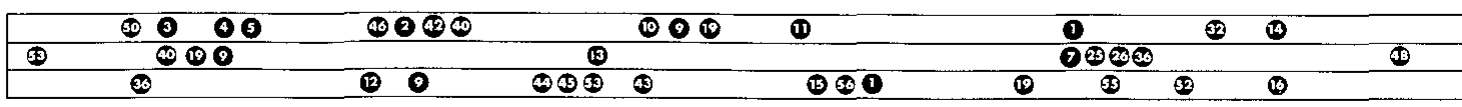
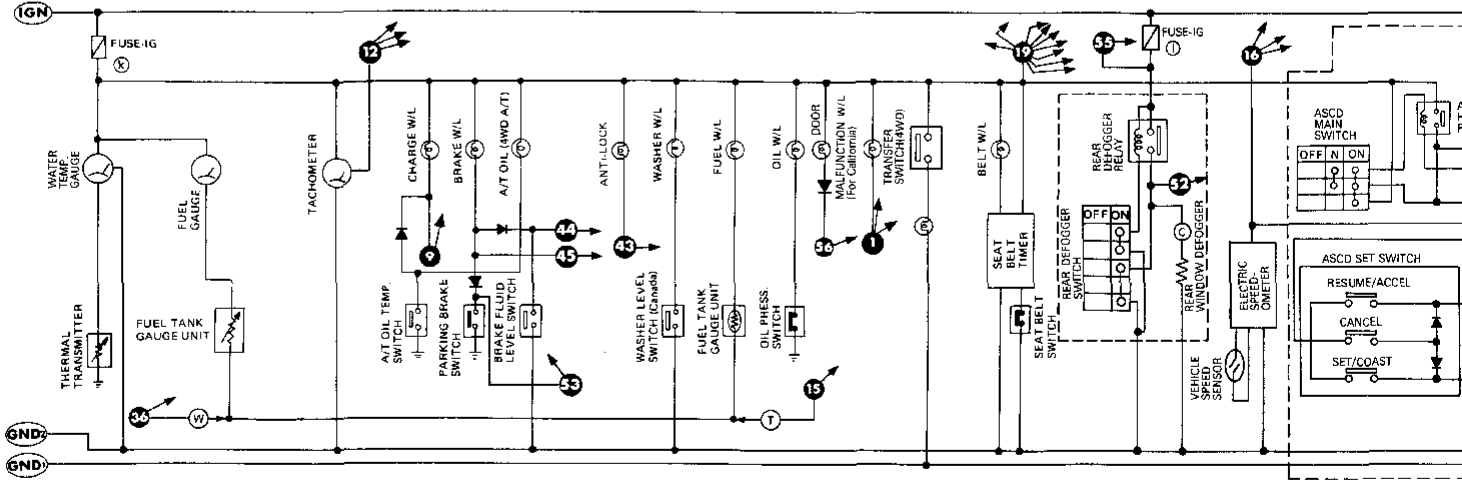
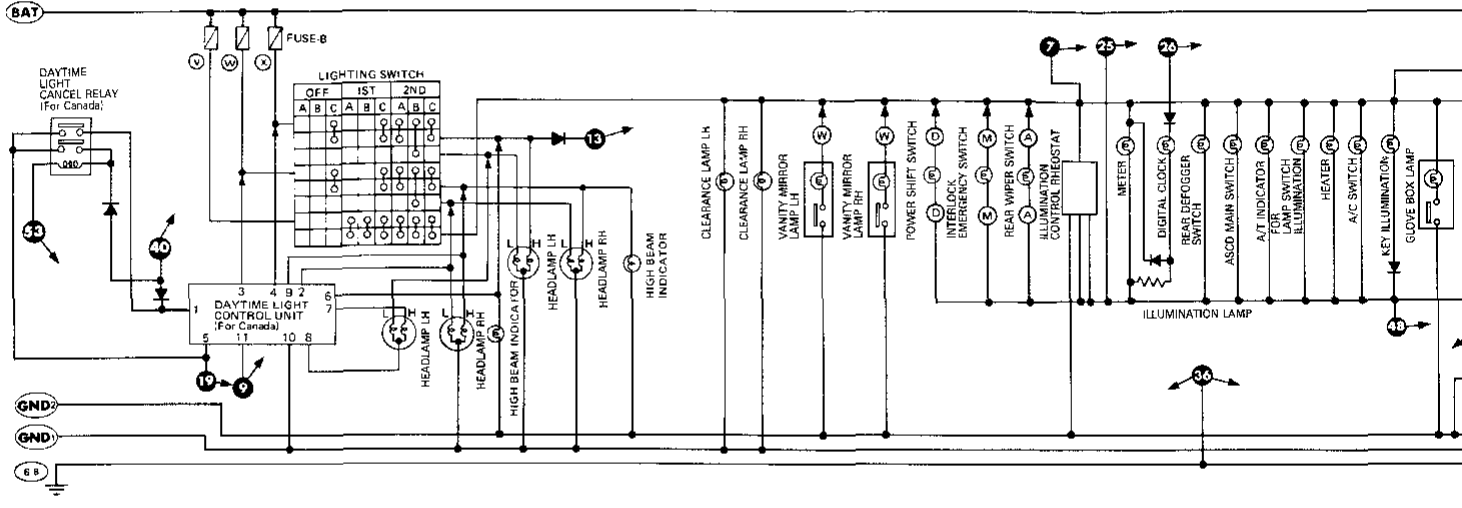
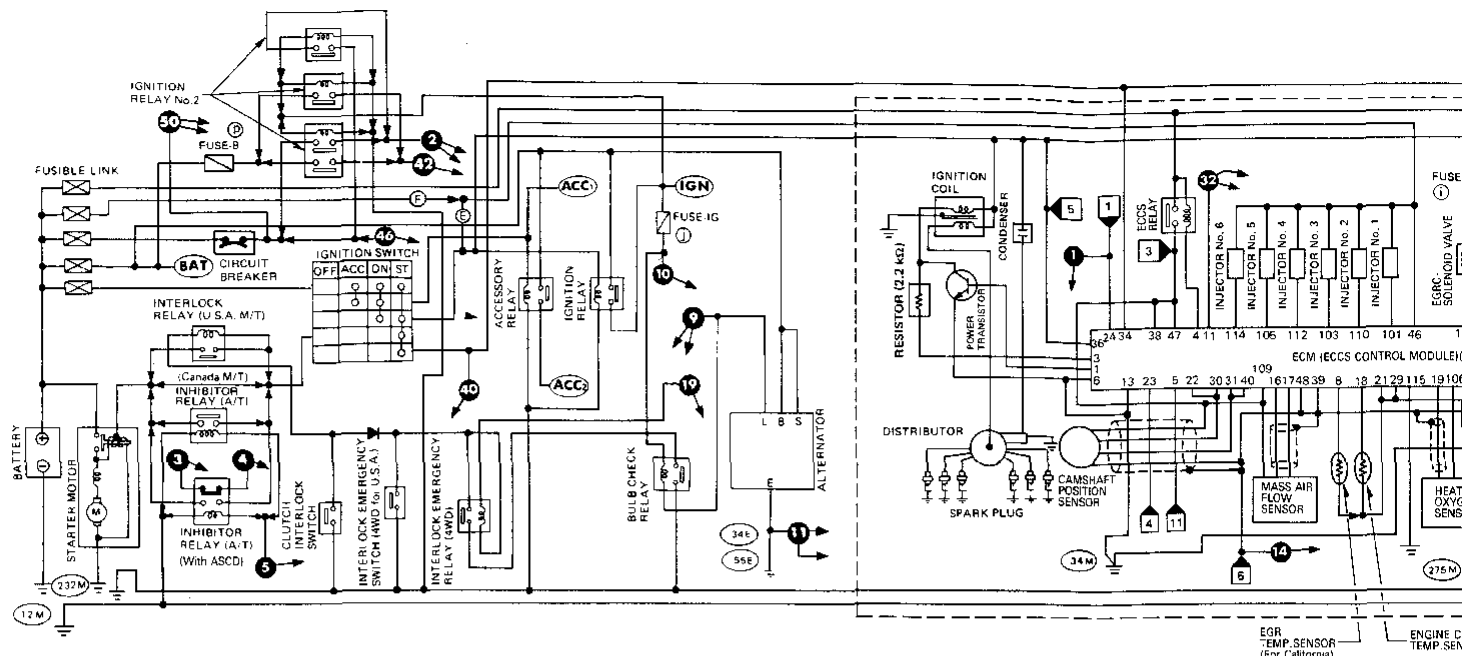

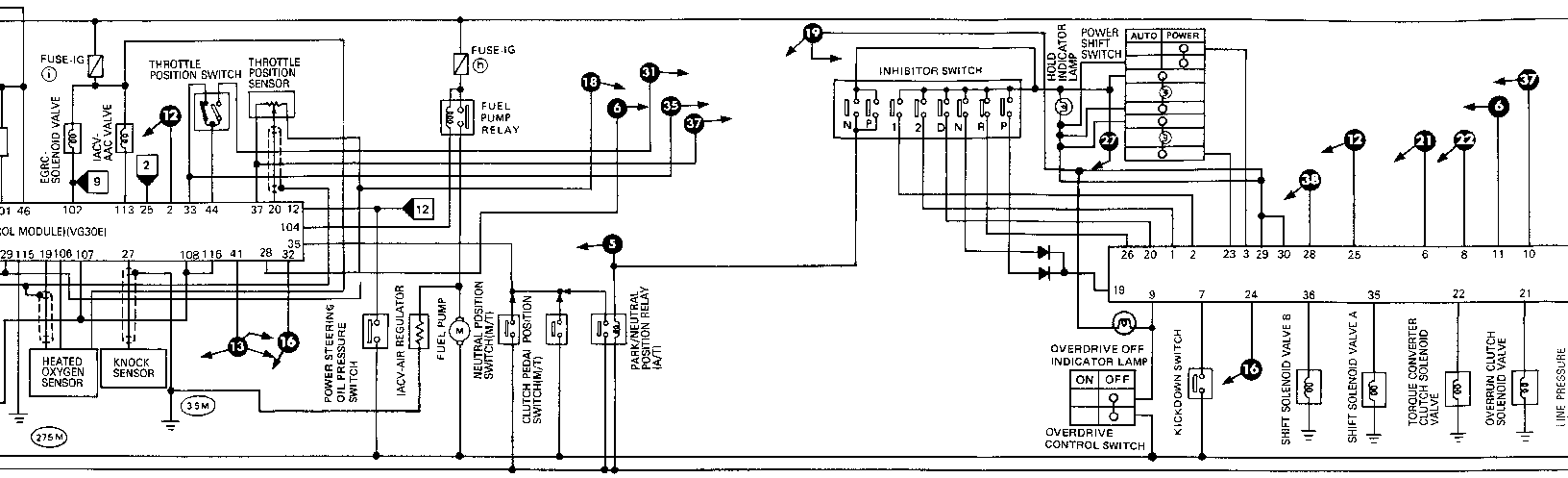

ENGINE COOLANT TEMP. SENSOR (VG30E engine model)

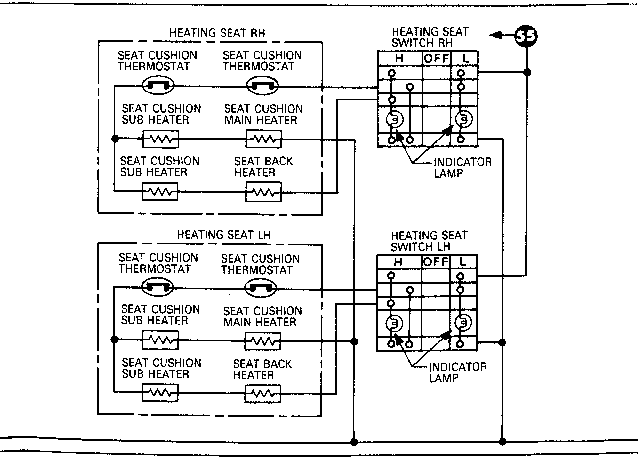
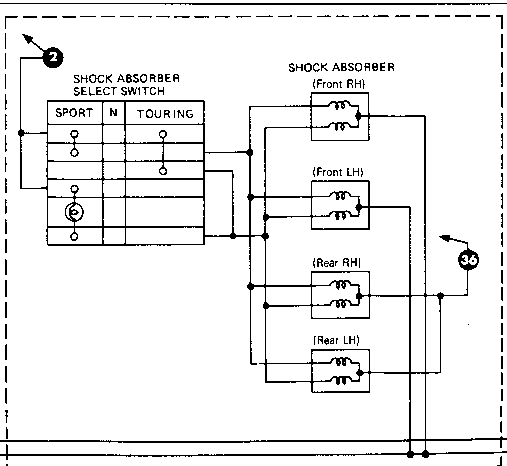
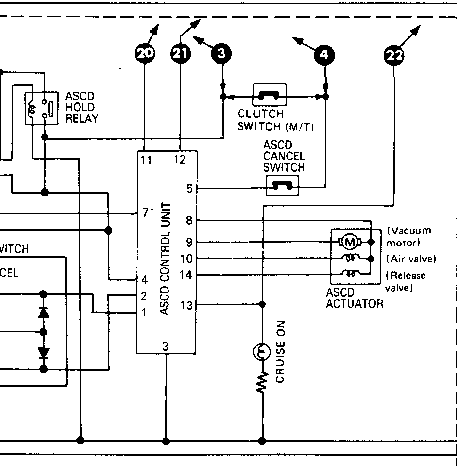
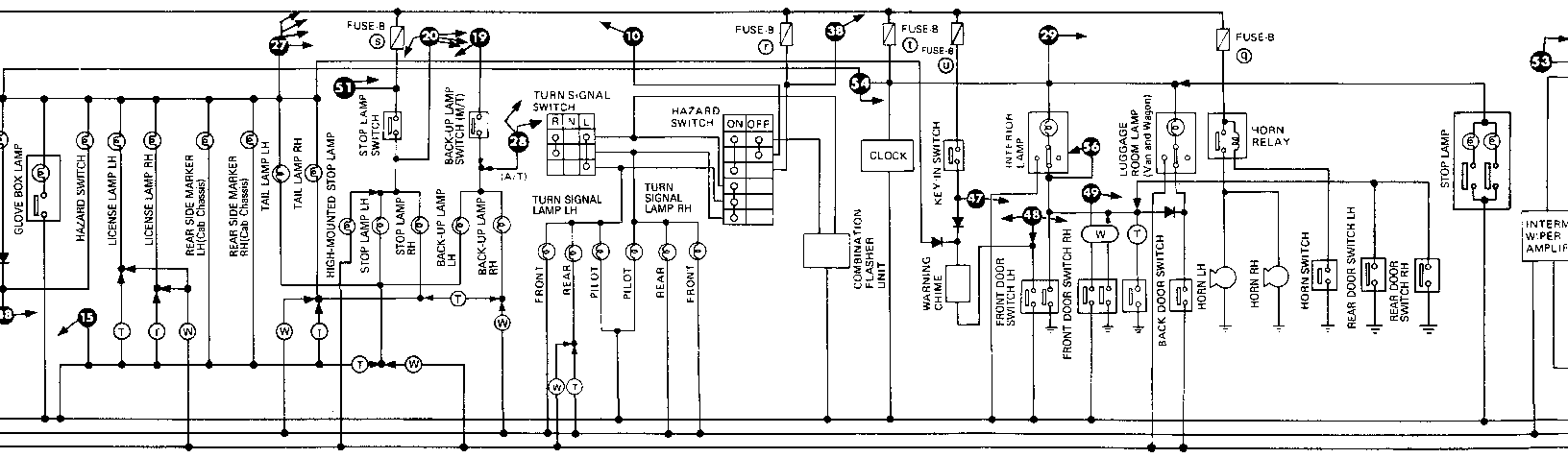

(VG30E engine model)

(Van and Wagon)

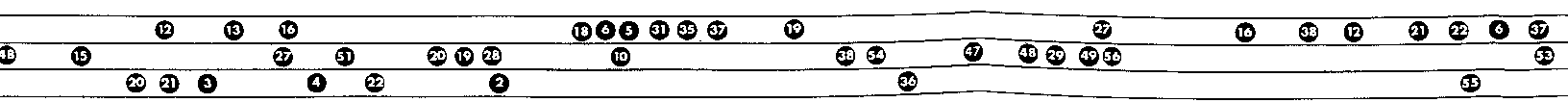

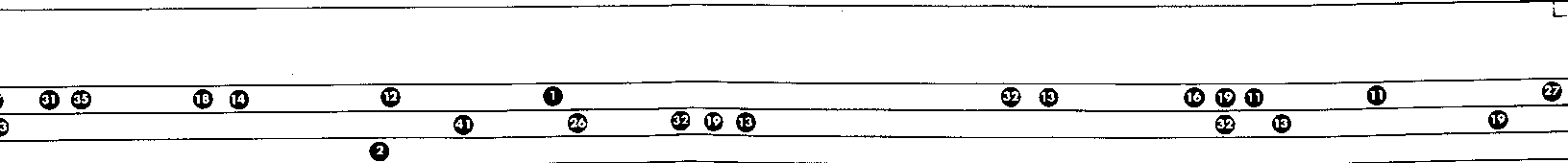
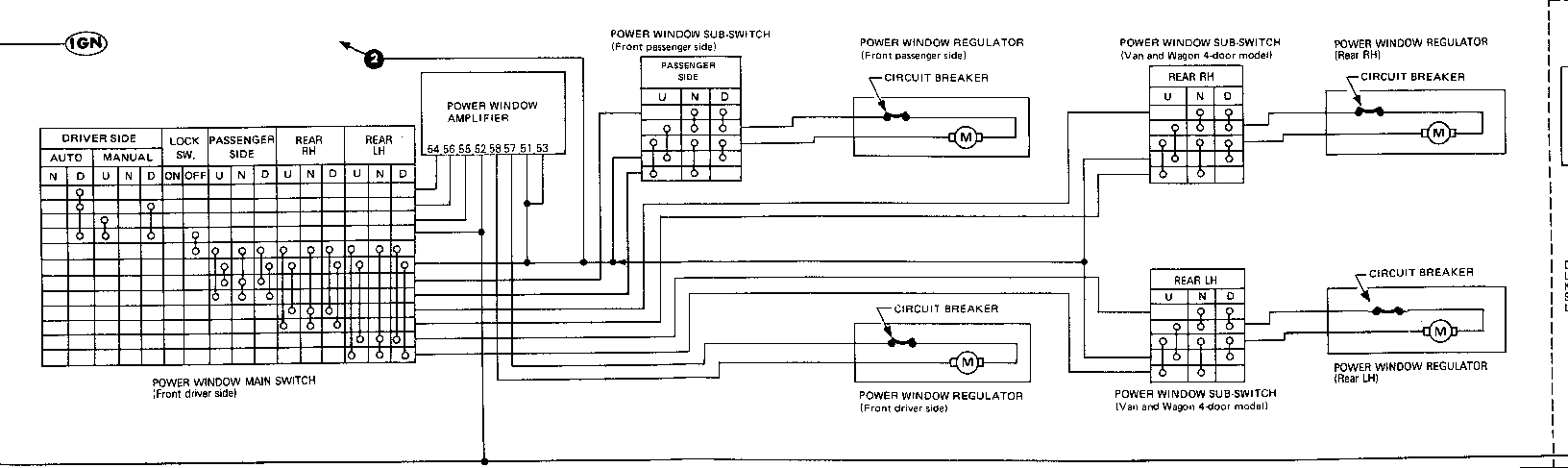
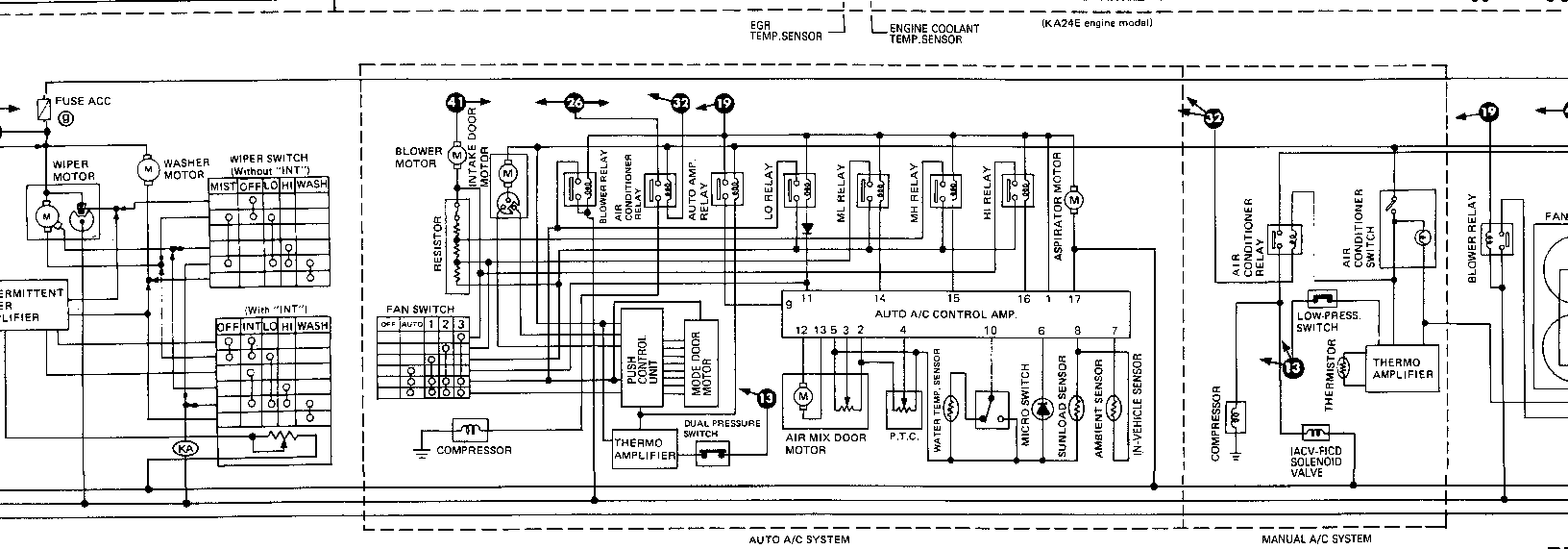
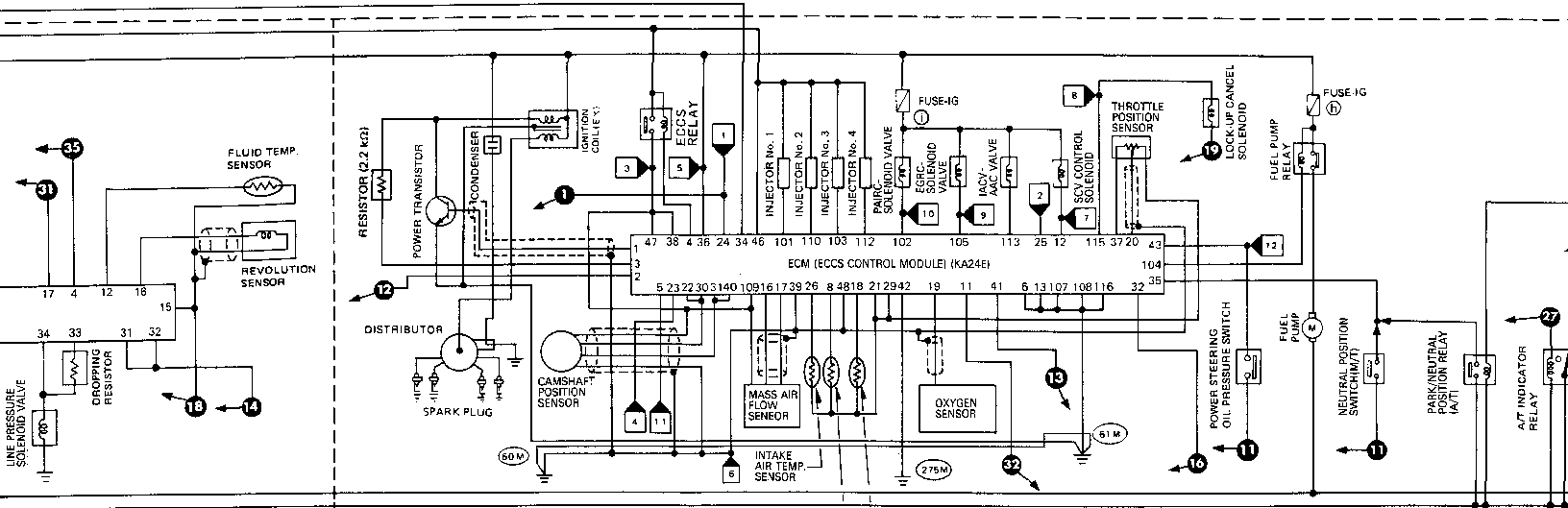

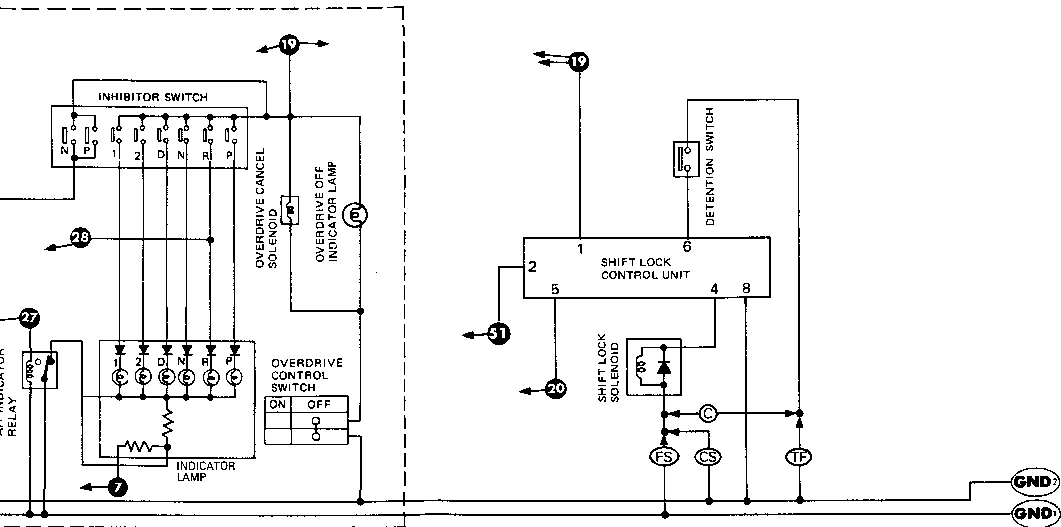

- (A) : With rear wiper
- (B) : Without rear wiper
- (C) : Except (TF)
- (D) : Van and Wagon A/T model
- (4WD) : Van and Wagon 4-wheel drive M/T model for U.S.A.
- (TF) : Truck floor shift model
- (CS) : Column shift model
- (FS) : Floor shift model
- (VB) : VG30E engine model
- (KA) : KA24E engine model
- (T) : Truck
- (W) : Van and Wagon
- (4D) : 4-door model
- (2D) : 2-door model
- (6S) : 6-speaker model
- (8S) : 8-speaker model

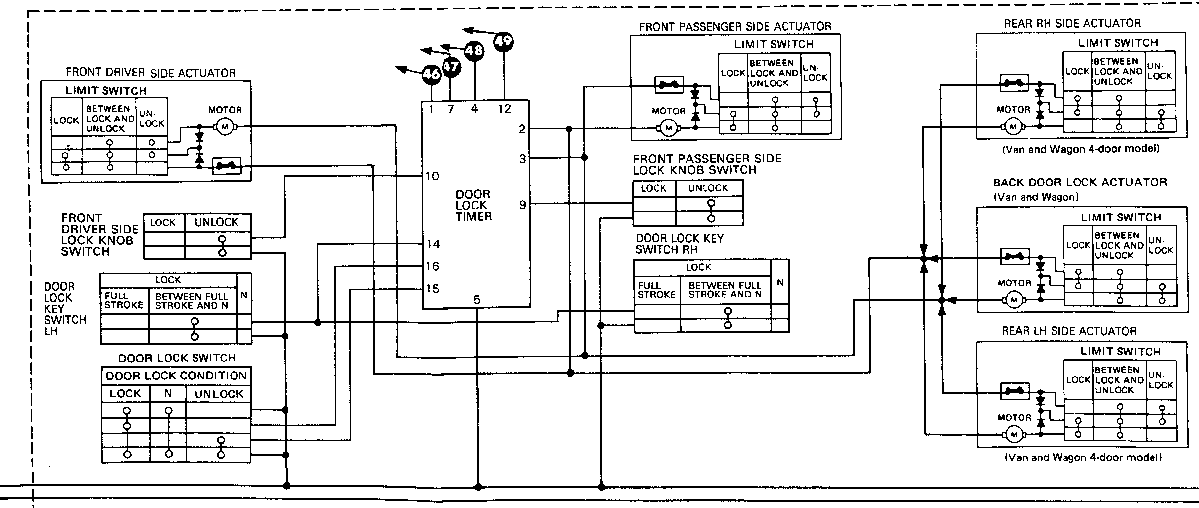
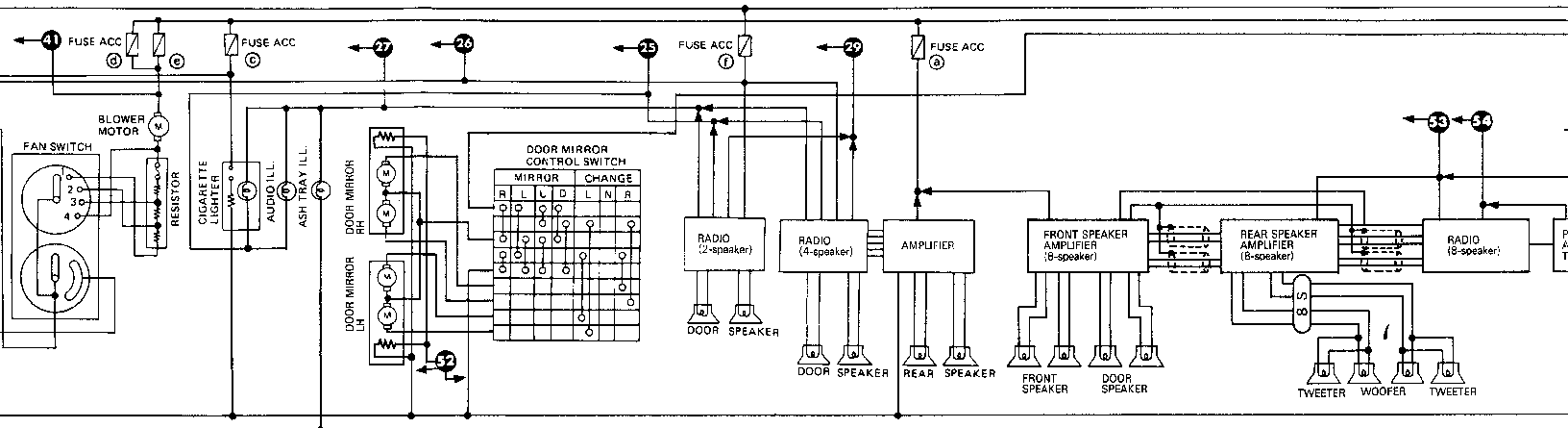

(Van and Wagon)

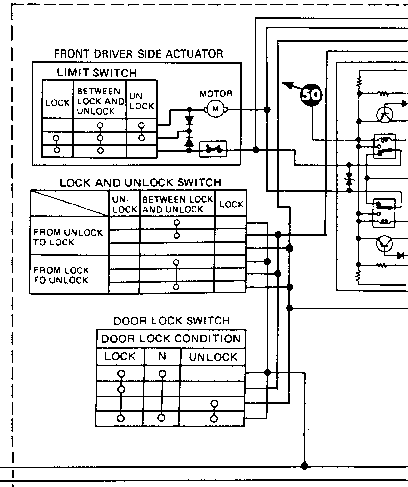

(Truck)

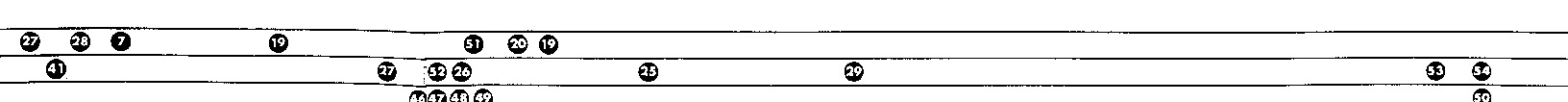

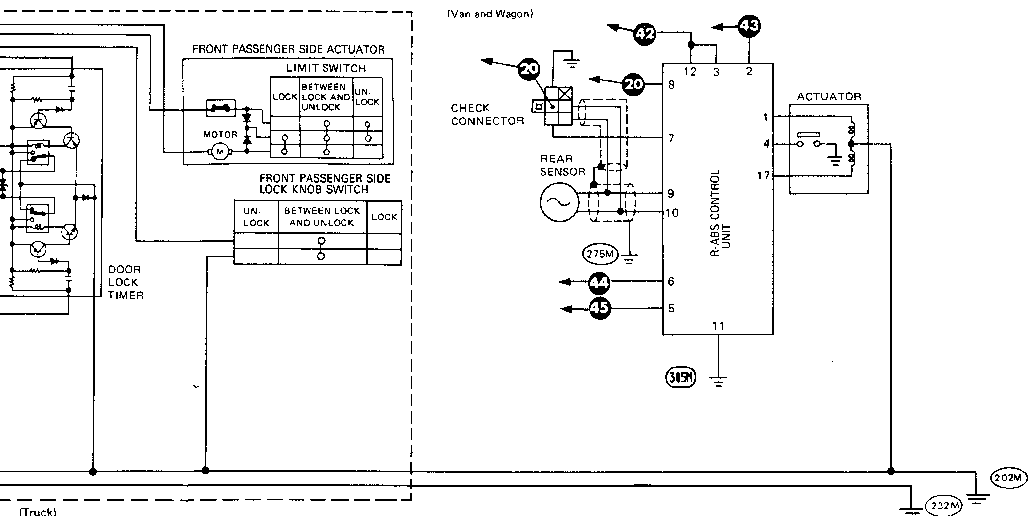
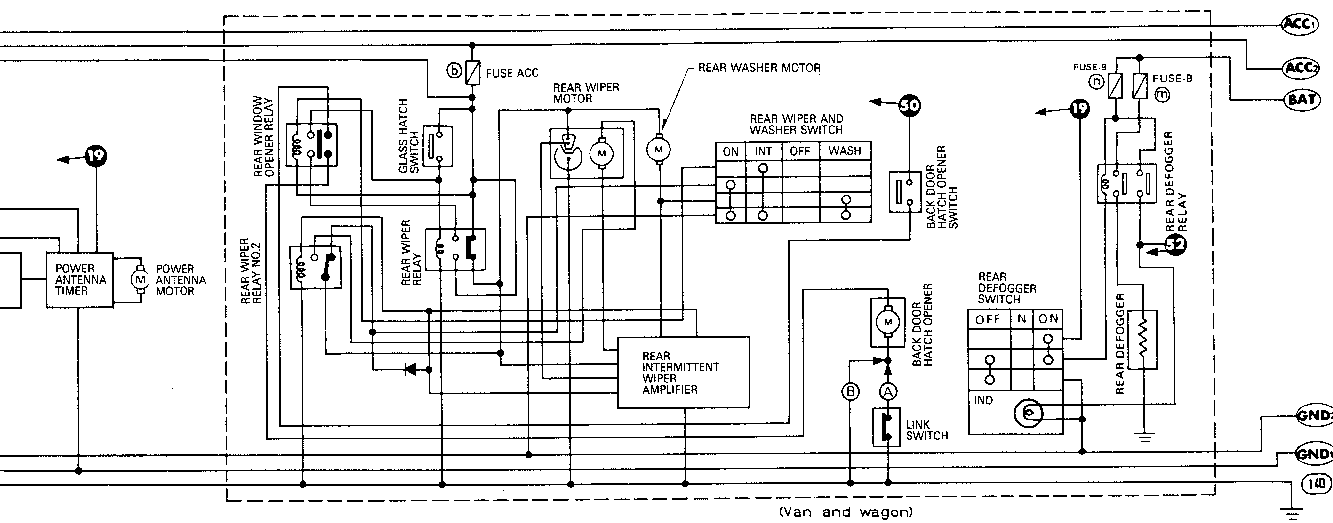
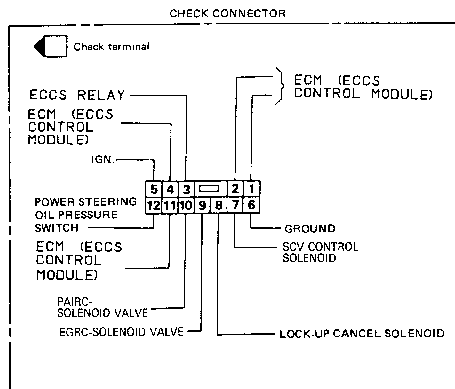
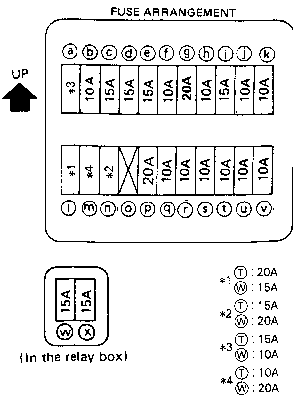

SEL810S

19 50 17 52

20 44 45 20 42 43